

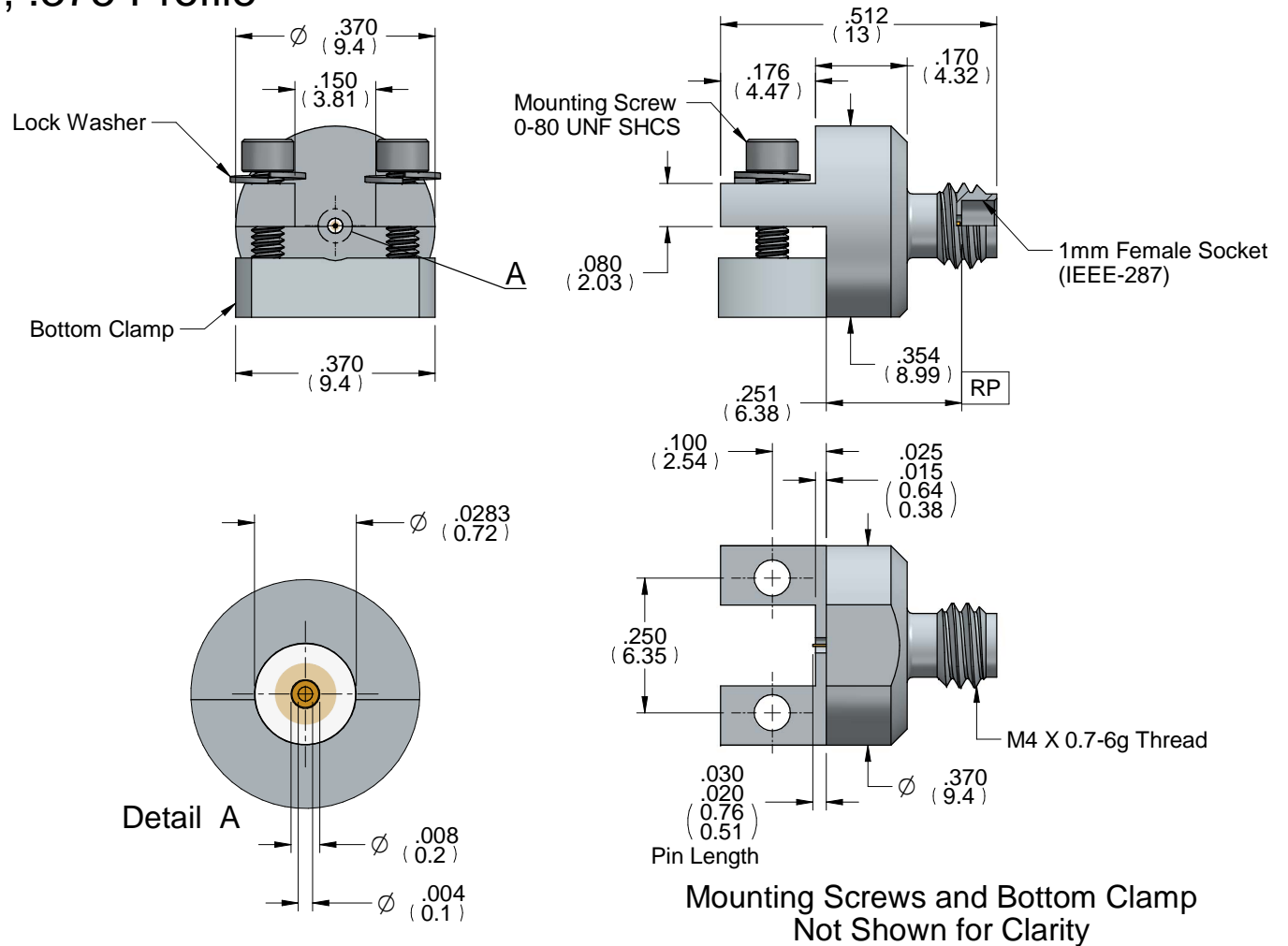

ELF110-001

1mm Edge Launch, .375 Profile

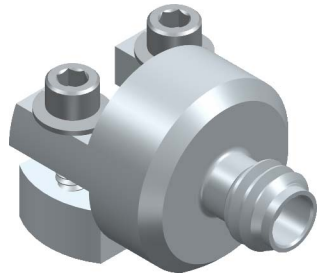

Board Mounting Detail

Notes (Unless Otherwise Specified):

1. All dimensions are in inches.
2. All angles are in degrees.
3. Dimensions in [xxx] are in millimeters.

MATERIAL TABLE

ITEM	MATERIAL
Housing and Bottom Clamp	303 Stainless Steel, Steel Cres Alloy UNS S30300 per ASTM A582 Passivated Per AMS2700 Method 1Type 2
Dielectric	Neoflon per ASTM D1430
Center Conductor	BeCu Alloy UNS C17300 Cond. TH04 per ASTM B196, Gold Plated per MIL-DTL-45204

APPROVAL	DATE	DWG NO	REV
BR	02/02/22	ELF110-001	C
FILE NAME: ELF110-001 Outline.dft			SHEET 1 OF 1