

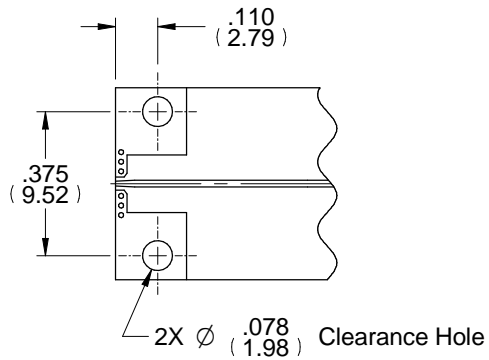

ELF40-002

2.92mm Edge Launch, .500 Profile

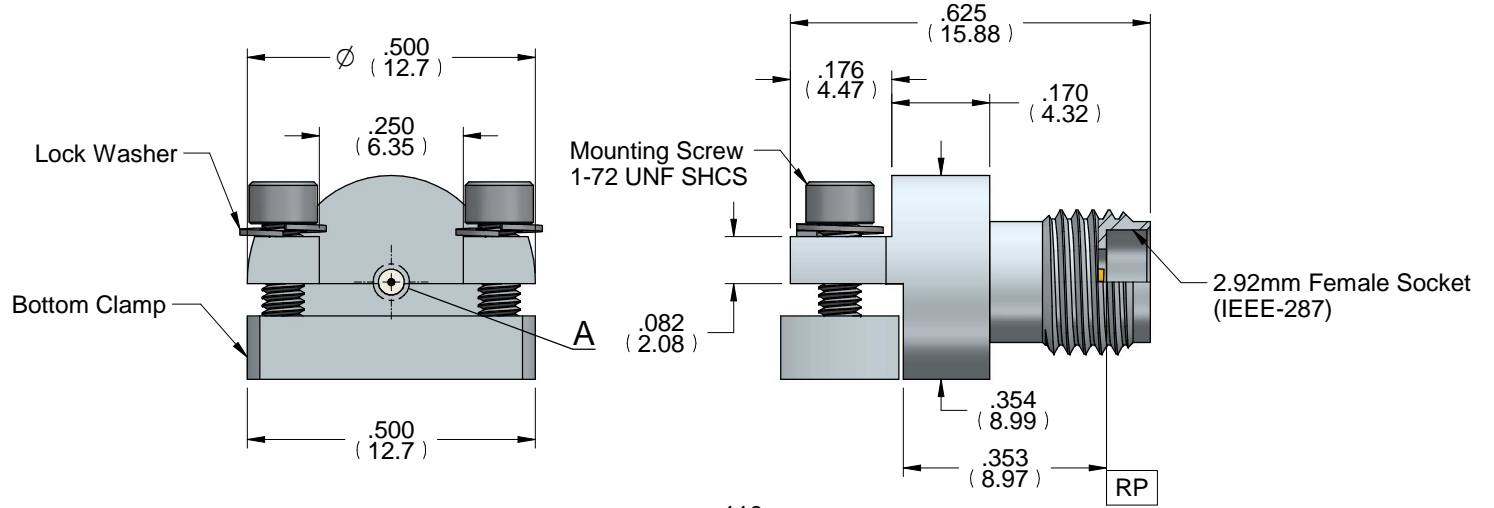
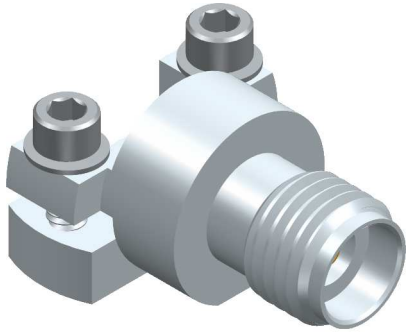

Board Mounting Detail

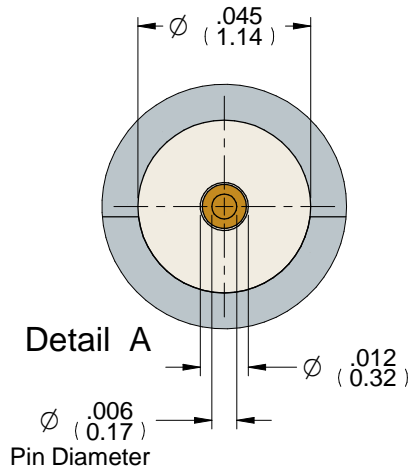

Detail A
Pin Diameter

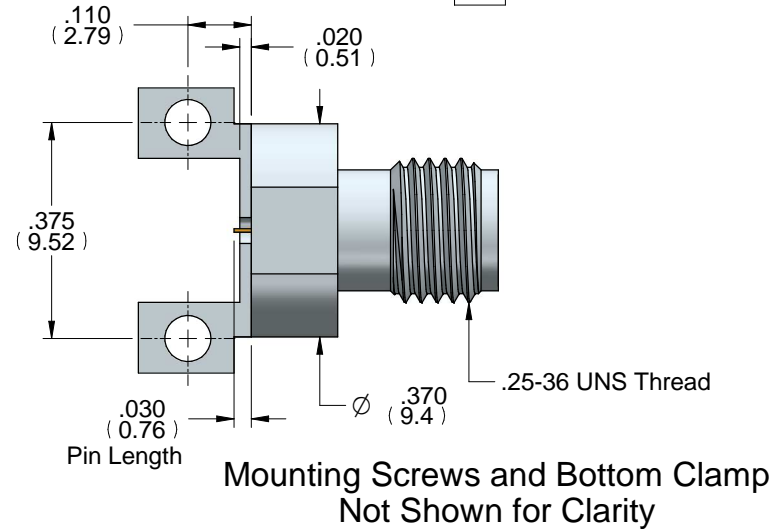

Mounting Screws and Bottom Clamp
Not Shown for Clarity

Notes (Unless Otherwise Specified):

1. All dimensions are in inches.
2. All angles are in degrees.
3. Dimensions in [xxx] are in millimeters.

MATERIAL TABLE	
ITEM	MATERIAL
Housing	303 Stainless Steel, Steel Cres Alloy UNS S30300 per ASTM A582
Dielectric	Neoflon per ASTM D1430
Center Conductor	BeCu Alloy UNS C17300 Cond. TH04 per ASTM B196, Gold Plated per MIL-DTL-45204

APPROVAL	DATE	DWG NO	REV
BR	12/14/16	ELF40-002	E
FILE NAME: ELF40-002 Outline.dft			SHEET 1 OF 1