

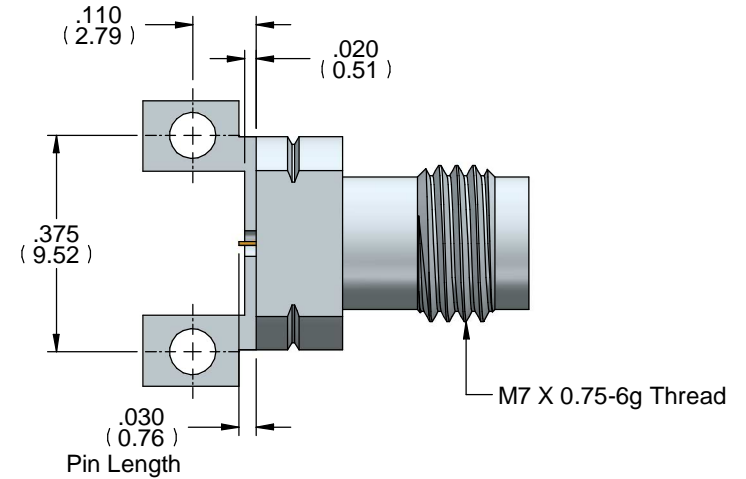

ELF67-002

1.85mm Edge Launch, .500 Profile

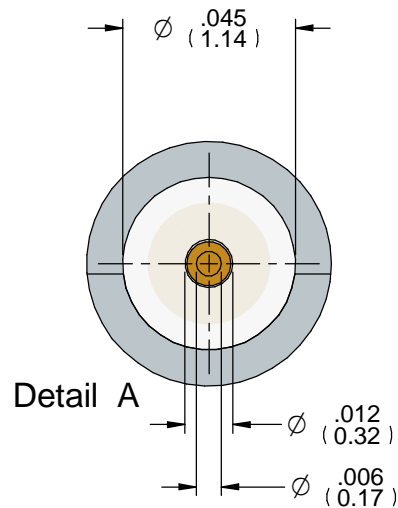
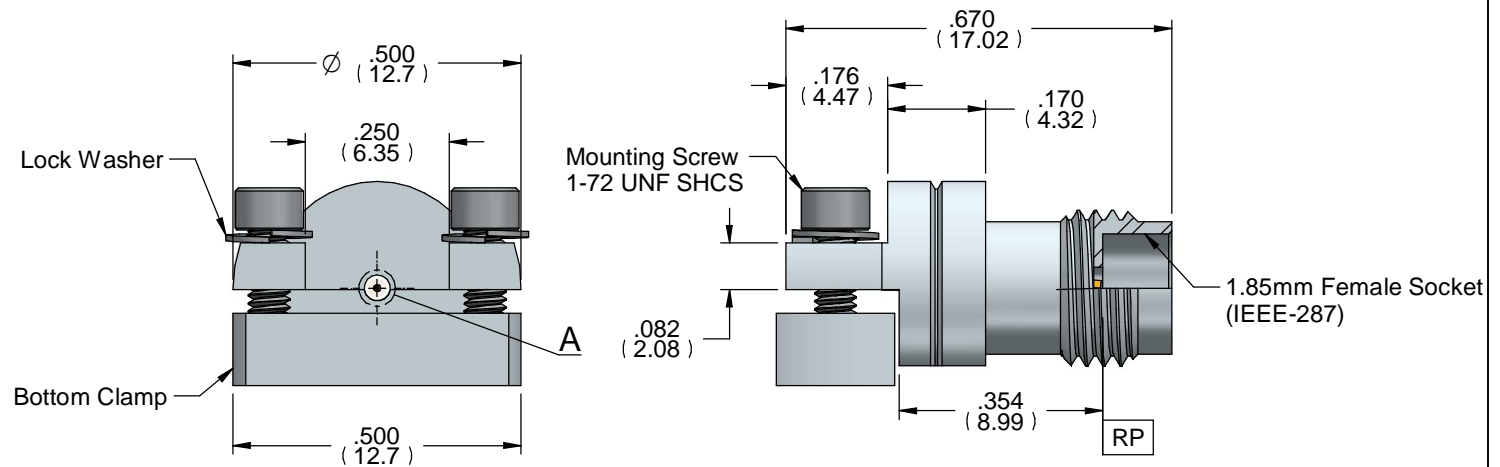
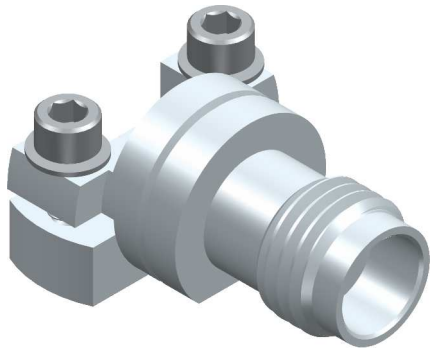

Mounting Screws and Bottom Clamp
Not Shown for Clarity

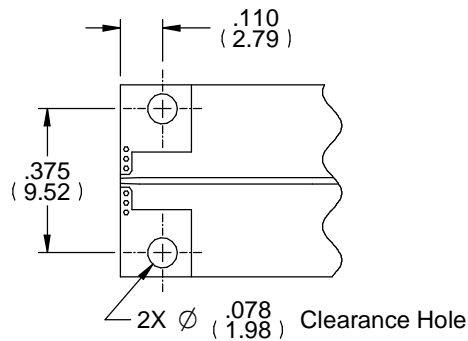

Board Mounting Detail

Notes (Unless Otherwise Specified):

1. All dimensions are in inches.
2. All angles are in degrees.
3. Dimensions in [xxx] are in millimeters.

| MATERIAL TABLE | |
|------------------|---|
| ITEM | MATERIAL |
| Housing | 303 Stainless Steel, Steel Cres Alloy UNS S30300 per ASTM A582 |
| Dielectric | Neoflon per ASTM D1430 |
| Center Conductor | BeCu Alloy UNS C17300 Cond. TH04 per ASTM B196, Gold Plated per MIL-DTL-45204 |

| | | | |
|----------------------------------|----------|-----------|--------------|
| APPROVAL | DATE | DWG NO | REV |
| <i>BR</i> | 07/17/15 | ELF67-002 | C |
| FILE NAME: ELF67-002 Outline.dft | | | SHEET 1 OF 1 |